

Are You Making the Most Out of Your Electrical Safety Tester? Exploring the Benefits of Using Simple Relay Control

Introduction

When performing electrical safety tests on the production line, manufacturers often find themselves between a rock and a hard place: minimizing production costs while maintaining throughput and increasing efficiency. While safety testing is an integral part of the manufacturing and production process, it can seem a burden when performed manually using handheld probes. Yet with advances in the industry, even the most basic testers provide test operators with other more efficient ways to test.

Hipot tester manufacturers have said goodbye to the older transformer-in-a-box design, giving way to smarter testers capable of performing fully automated test sequences. While some high-end testers can be connected to a PC, the majority of modern safety testing equipment still affords operators some level of basic automation.

Simple Relay Control

A common offering is the addition of a set of internal input relay contacts, usually accessible via a standard DB-style connector. These contacts can be used to send signals to the microprocessor-controlled “brain” of the tester. Consider the Signal Input Connector of the Slaughter Model 1305 Hipot tester:

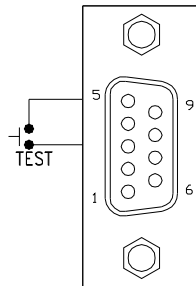

Figure 1.0: Slaughter Model 1305 Signal Input Connector

This model comes equipped with a set of input contacts accessible through the connector which may be used to signal the instrument to enable a test. Pins 3 and 5 provide the operator with a direct connection to simple circuit and ground. All the operator needs to do is to provide a switch between these two pins so that when closed, the tester will perform a test. The switch can be anything from a foot switch to a palm switch to a push button. The real benefit of this design is that the test operator can customize the method in which the tester is signaled.

Still other Hipots are available with a wide variety of input and output controls, giving the test operator more flexibility in setting up and performing tests. Consider the Slaughter Model 2550 which has a Remote I/O Connector that comes with 3 inputs and 3 outputs.



Figure 2.0: Slaughter Model 2550

Using simple switches and basic circuit theory, the test operator now has full control over both the TEST and RESET functions of the instrument. For manufacturers whose primary concern is the safety of the test operator, the INTERLOCK input gives access to a “test-override” circuit. Pins 4 and 5 must be shorted together in order for the tester to perform a test. If for any reason these two pins become disconnected from each other, the tester will stop a test in process or prevent a test from being performed.

The applications for this feature are numerous. Primarily developed as an added safety feature, manufacturers have used the Interlock feature with anything from plastic test enclosures to light curtains to emergency off buttons.

Still other testers come equipped with multiple output signals as well. In addition to being able to input simple commands like TEST and RESET, the Slaughter Model 2550 also provides several output signals including PASS, FAIL, PROCESSING.

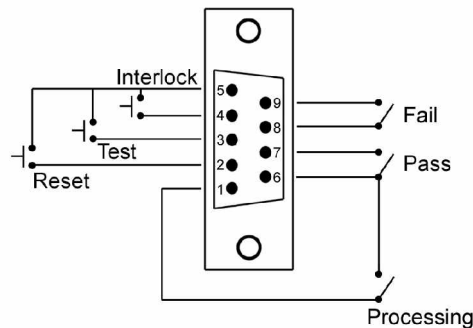

Figure 3.0: Slaughter Model 2550 Remote I/O Connector

Each condition is signaled by a change of state (opening or closing) in the signal's corresponding relay. Operators have access to alternate poles of a relay so that they may connect to it an indicating device such as a light or an alarm. Again, this technology offers operators near unlimited possibilities in determining the method of indication that works with a particular application.

Advanced Options

Some manufacturers require more than just simple TEST and RESET inputs. Keeping this in mind, some machines allow operators to select and execute a particular test stored in the instrument's memory. The Slaughter Model 4320 comes equipped with this capability which can be seen in Figure 4.0.

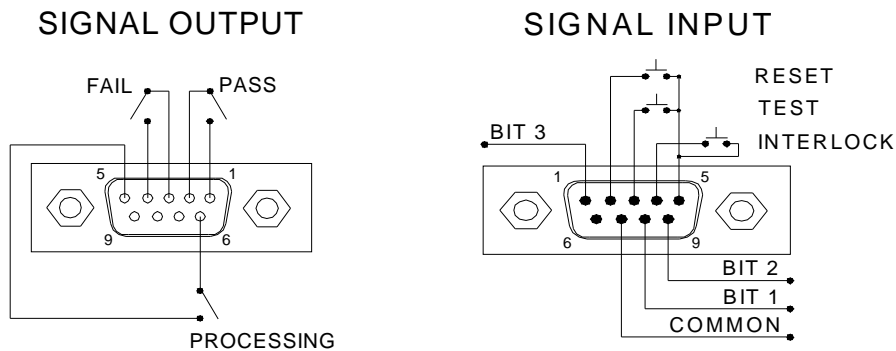

Figure 4.0: Slaughter Model 4320 Remote I/O Connectors

If a technician usually performs different safety testing routines on several products, he need only signal the tester which routine to execute using an input signal to the tester's Remote Input Connector. The Slaughter Model 4320 allows operators to select and execute from 3 different test memories all with the push of button.



Figure 5.0: Slaughter Model 4320

Conclusion

While some safety testing instruments may seem overwhelmingly complex with their multitude of computer-controlled capabilities, more basic forms of remote control do exist. Using simple relay control, many manufacturers have implemented a safer and more efficient safety testing routine. No matter what the level of complexity, from simple push buttons to advanced light curtain and interlocked enclosure test stations, there are options out there for anyone interested in automating or upgrading an outdated safety testing routine.